

## PitchFork Installation Manual

### Guidelines/Restrictions:

- This carrier is intended for Thule® rectangular and Yakima® round bars only.
- Bicycles must be equipped with quick release front wheel.
- Minimum crossbar spread is 16 inches, maximum 40 inches.
- Do not exceed the load capacity of your vehicle's roof rack.
- Bicycle weight limit is 35lbs with this carrier.
- Forks equipped with carbon fiber dropouts or forks without safety tabs are not covered under this warranty.

**Step #1** If you have a Thule® bar, remove the insert (Figure #1) in the Bar Clip. If you have a Yakima® bar, leave insert in place (Figure #2)

Figure #1



Figure #2



Figure #3

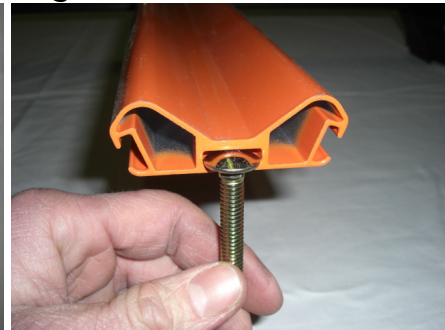

**Step #2** Place the Bar Clip around the rear bar (Figure #2). Slide the 2" Carriage Bolt into the rear of the Wheel Tray (Figure #3). Hold the Wheel Tray over your crossbars and feed the bolt through the hole of the Bar Clip (Figure #4).

Figure #4



Figure #5



Figure #6



**Step #3** Remove the black plastic Cover Plate by pulling on the tab and place the head on the front crossbar (Figure #5). Hook the gold Under Bar Plate in the front of the head and push up (Figure # 5). Squeeze the Under Bar Plate and head together, and drop two Allen Bolts with Split Washers through the top of the head and tighten with a 5mm Allen Wrench (Figure #6).

*If you purchased one lock core, remove the plastic plug in the handle of the Quick Release. With the key in the lock core, line up the thin protruding tab on the end of the lock core with the two arrows on the inside face and press in. If you purchased a second lock core to lock the rack to the car, break out the round tab (about the size of a dime) centered in the Plastic Cap, and install the lock here. Follow the icons for locked and unlocked positions.*

Re-install the black plastic Cover Plate (Figure #7). Unthread the Quick Release Skewer, and install into the head by threading together inside. Have the handle face towards the outside of the car.

Figure # 7



Figure #8



Figure #9



**Step #4** Thread the WingNut onto the bolt of the Bar Clip and tighten firmly (Figure#8).

**Step # 5** Install the Wheel Strap into the slots on the side of the Wheel Tray with the buckle facing out (Figure #9). If it is a snug fit, a rubber mallet can be used to tap it in. Line up the two sides of the End Cap and insert it into the end of the Wheel Tray (Figure #10).

Figure #10



**Note:** When the Quick Release is closed firmly and locked, it covers the bolt heads and the rack cannot be removed. You must close and lock the Quick Release after removing the bike to re-lock the rack to the crossbar. If you purchase a second lock, you can break this tab out, install the lock and the rack will always be locked to the car.

The quick release handle can be turned (unscrewed) even when locked. To prevent a thief from doing this, the handle of the quick release must hit the crossbar when rotated. To test, try turning the handle counter-clockwise when closed. If it does not hit the bar, loosen the bolts and reposition the bike rack further in on the rack until the handle hits the crossbar when closed.

### To Load a Bicycle

#### Step 1:

Remove front wheel from bicycle. Open the handle of the quick release so the black handle is straight and the fixed end points down. Load the fork onto the quick release so both fork ends are resting straight on the quick release. Close the handle by flipping it 90 degrees to the closed position. If it is too loose, open the handle and turn it like a screwdriver (clockwise to tighten, counter clockwise to loosen), and close the handle again. Re-adjust until a firm and positive snap is felt when closed.

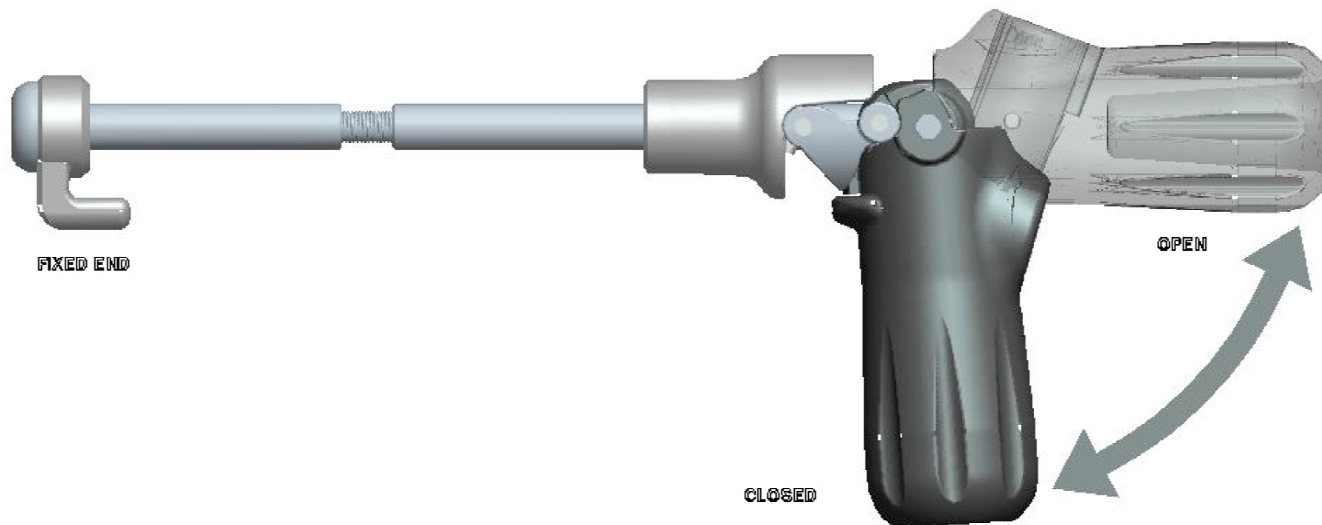

The Quick Release Skewer is not an on/off switch. You must close the handle with enough

tension to hold the bicycle.

Rock the bicycle side to side to ensure proper mounting. The fork should be properly seated and not move. If unsure, please consult your dealer or RockyMounts. Failure to comply could result in the bicycle detaching with subsequent damage to the bicycle, vehicle, or other motorist.

**Step 2:**

Fasten the Wheel Strap by looping the end through the wheel and into the buckle. Pull on the end until the strap firmly contacts the wheel.

**Maintenance:**

Once a year, remove the rack from the car, clean and inspect for damage. Replace any worn components. Put a drop of oil (chain lube, motor oil etc.) on the metal pivot points, threads and axle of the Quick Release.

**Note:** Position your bike mount at least 3" in from the end of the bar, this will prevent the Quick Release handle from being turned in the lock position.

**Caution:**

- Remove Baby Seats, Panniers, U-Locks or items which could detach from the bicycle.
- Do not use bicycle covers, bicycle bras, or bikes equipped with disc wheels.
- Do not take the vehicle off road, if you must, drive cautiously.
- Locks are only deterrents to thieves, RockyMounts cannot be held liable for stolen bicycles.
- Remove rack before entering a car wash.
- Check all fastenings (nuts, bolts, straps and skewer) before each use.

### One Year Limited Warranty

Rocky Mounts Inc. Warrants to the original purchaser that the product will be free from defects in material and/or workmanship for one (1) year from the date of original retail purchase. Subject to the limitations stated below, Rocky Mounts will at its own expense during the one year warranty period repair or replace the defective component(s). The purchaser will be responsible for freight charges to Rocky Mounts. This warranty is only applicable if the instructions are correctly followed and the components are properly used. This warranty is not applicable if the defect is caused by normal wear and tear or exposure, the component(s) is damaged from misuse, abuse, theft, fire, accident, alteration, mixing third party components with the system and/or unlawful operation of the vehicle. Rocky Mounts Inc. cannot and does not assume responsibility for any damages to any property arising out of the improper attachment to a vehicle or a bicycle to the system or use of its products. This limited warranty applies to Rocky Mounts products and not to the products used in conjunction with Rocky Mounts products.

This warranty is in lieu of all other warranties, expressed or implied, and does not cover consequential damages of any kind arising from the use or misuse of Rocky Mounts products.

**ROCKY MOUNTS DOES NOT AUTHORIZE ANY PERSON TO ASSUME, ON ITS BE- HALF, ANY OTHER OBLIGATION OR LIABILITY.**